



U.S. Department
of Transportation
**Federal Highway
Administration**

1200 New Jersey Avenue, SE
Washington, D.C. 20590

July 10, 2009

In Reply Refer To:
HSSD/CC-105

Mr. Dallas James
Armorflex
P.O. Box 303 177
North Harbour
Auckland 0751 New Zealand

Dear Mr. James:

This letter is in response to your request for the Federal Highway Administration (FHWA) acceptance of a roadside safety device for use on the National Highway System (NHS).

Name of device: Armorwire ATE-4
Type of device: 4-cable barrier end terminal
Test Level: NCHRP Report 350 (modified) TL-3
Testing conducted by: Holmes Solutions
Date of request: January 15, 2009
Date of completed package: April 21, 2009

You requested that we find this device acceptable for use on the NHS under the provisions of National Cooperative Highway Research Program (NCHRP) Report 350 "Recommended Procedures for the Safety Performance Evaluation of Highway Features."

Requirements

Roadside safety devices should meet the guidelines contained in the NCHRP Report 350." The FHWA Memorandum, "Identifying Acceptable Highway Safety Features" of July 25, 1997, provides further guidance on crash testing requirements of longitudinal barriers.

Description

The Armorwire Terminal End for 3-cable barriers was the subject of FHWA Acceptance Letter CC-98 dated April 9, 2007. Your present request is for a similar terminal for 4-cable barriers. The ATE-4 terminal consists of the ground strut, trigger post, anchor cables, and other components as shown in the drawing enclosed for reference. A description of the major components follows.



Ground Strut

The ground strut is fabricated from mild steel conforming to ASTM A36. The ground strut was 1.9 meters long and supported by three reinforced concrete foundations at approximately 900 mm spacing. The ground strut foundations consist of three 450-mm diameter concrete piles that are 1000 mm long.

Trigger Post

The trigger post consists of a trigger release head, supported by two square section posts and fixed to the ground strut. The trigger release head is fabricated from hot rolled steel, galvanized after fabrication. The hot rolled steel complies with ASTM A36. The trigger release head is welded to two legs that are angled away from the release head. The head has five angled slots, two on each side and one on top, to accept the end fixing details of the cables from the wire rope barrier. A further central slot, open to the bottom of the head is provided to allow attachment of the two anchor cables. This head effectively joins the two cables that are attached to the ground strut to the four cables forming the barrier.

Anchor Cables

Two parallel 19 mm diameter by 2.0 m long wire rope anchor cables are fixed between the top of the trigger post and the opposite end of the ground strut. These pass through a tunnel section in the ground strut and are terminated, via a bolted connection, at the down stream end.

Wire Rope Barrier Cables

The four barrier cables were constructed using 19 mm 3 x 7 strand galvanized cable, prestretched by 35 percent. Cables are tensioned to a nominal 25 kN at an ambient temperature of 21 degrees Celsius. The cable breaking strain has an ultimate tensile capacity of 110 kN.

Rope Barrier

In the tested configuration the test article consisted of the ATE-4 terminal end attached to a 33 m length of Nucor Test Level 4 (TL-4) cable barrier. All foundation elements were embedded in AASHTO "standard" soil. The wire ropes were attached to the posts at heights of 380, 690, 790, and 890 mm above ground level. The cables at 380 mm (bottom cable), and 890 mm (top cable) being attached to the impacted side of the post. The remaining two cables (at 690 mm and 790 mm height) were attached to the opposite side.

Comparing ATE-4 to the original ATE

The key element of the ATE-4 is the trigger post assembly and foundations. The trigger post forms a junction between the anchor cables and the barrier cables, where the cables are located in slots and held in place by the barrier tension. When a vehicle impacts on the end of the barrier, the two terminal cables projecting from the ground strut are required to release from the terminal head, allowing the trigger post to bend backward under the tension of the barrier cables and releases the barrier cables out of the top of the trigger head, thereby releasing the tension from the barrier. For impacts after the Length of Need (LON), the terminal end is required to have sufficient strength and stiffness to remain an integral part of the barrier, providing normal re-directive performance.

The basic operating principles of the ATE-4 and the original three cable terminal end design are the same. Both systems utilize an angled slotted hole, open at the bottom to attach the anchor cables. When impacted end on, the cables are forced downward out of the slot releasing the tension in the barrier. The means of attaching the cables from the barrier are different between the two systems. The original system used a central slot into which the three cables were located. The cables were provided with lateral support and were only capable of exiting the trigger head in a vertical direction. All cables were located on the centerline of the system and position directly in line with the anchor cables. The ATE-4 uses a series of four offset angled slots, located with two on either side of the impact head. The slots are open laterally thereby allowing the cables to be released sideways and also by prying or rotation of the connection detail. It is unclear if lateral deflection of the cables near the terminal post would cause sufficient rotation such as to dislodge the cables from their slots, however it is considered unlikely that this would influence the gating length of the system. Both the original three wire ATE and the new ATE-4 have a LON of 8 m incorporating 4 line posts at 2 m centers.

The ATE-4 also uses a bolted trigger post detail, comprising of two sections. This provides the trigger post with greater lateral stability and strength than the original design. The original ATE used a single mild steel post, located in a cast-in socket. The alignment between the anchor cables and the barrier cables in the ATE-4 has less eccentricity than the original design, reducing the potential for imposed moments in the trigger head. This reduces the potential of the system to result in out-of-balance forces when impacted along the length of the barrier. The lateral location (side mounted) of the cables in the trigger increases the potential for lateral rotation of the head under an impact.

The ATE-4 has additional tolerance for the height of the cables in the wire rope barrier. Recent four cable barriers, particularly TL-4 cable barriers, tend to have higher cables that will have a greater propensity to ride over the hood of an 820C vehicle and cause damage to the A-pillar when struck in a reverse direction impact. For the purpose of this test, the NUCOR TL-4 cable barrier system was selected as the top two cables are set at 890mm and 790mm respectively from ground level.

Evaluation of NCHRP Report 350 Test Matrix

The NCHRP 350 calls for a series of seven tests to validate the crash worthiness of a gating terminal end. The original ATE terminal end was subjected to a reduced matrix of four tests. This testing program was established in consultation with the FHWA and was based on previous testing programs of other wire rope terminal end systems. The four tests completed were 3-30, 3-32, 3-35 and a modified 3-39. As is industry practice, test 3-39 was modified from using a 2000P to using an 820C test vehicle as it was felt this posed the greatest potential for occupancy harm.

The changes between the original three wire ATE and the new ATE-4, described in the previous section, were considered to have little impact on the crashworthiness of the system and as such the system could be validated using a further reduced test matrix. The rationale for the reduced testing matrix is provided below.

Tests 3-30 and 3-32

In end on impacts such as in tests 3-30 and 3-32, the anchor cables and the ground strut have remained unchanged between the ATE-4 and the original system. The washers joining the two anchor cable ends and the angle at which the washers sit in relation to the anchor cables are also unchanged. The failure mechanism, namely the anchor cables being forced out of the bottom of the slotted details, is identical to that already tested with the original ATE and therefore it is deemed unnecessary to retest the new design to tests 3-30 and 3-32.

Test 3-35

Test 3-35 is used to evaluate the required length of need of the system. The original three cable ATE system was tested and successfully met the acceptance criteria for this test. The ATE-4 system has an additional cable which should make the barrier system stronger than the previously tested system. The new ATE-4 system attaches the barrier cables to the trigger post using slots located on the side of the trigger head. As with the original ATE, the new trigger post is set at an angle so that during any longitudinal barrier impacts, such as test 3-35, the cable end fittings are pulled down into their respective receptacles, removing any possibility of them releasing prematurely.

The cables release from the trigger head of the new ATE-4 laterally. This release mechanism has the potential to release a cable due to prying of the cable end fitting or rotation of the trigger head detail. These forms of release action could potentially be caused by a redirect impact close to the trigger post. Test 3-35 is used to evaluate the length of need (LON) of the system with an impact occurring some distance downstream from the trigger post. The LON of the new ATE-4 is 8 m, incorporating 4 cable barrier line posts at 2-m centers. This is an identical LON to the previously tested three-wire ATE system. It was considered unlikely that the forces induced by Test 3-35 would cause prying of the cables or rotation of the trigger post head and therefore it was considered unnecessary to repeat this test on the modified ATE-4 system.

Test 3-39 Modified

The release mechanism and geometry of the four cables at the top of the trigger post has been altered in the new ATE-4 system. The cable end fittings are required to release laterally rather than vertically as in the original system. The influence of this design change can be evaluated using test 3-39. In addition, it was felt that the modified release mechanism of the trigger post increased the potential for the vehicle snagging when impacting from the reverse direction. In the reverse direction impact it was felt the vehicle had the potential to become wedged between the cables before impacting the trigger post. The cables must release at the trigger post in order for this test to be successful. It was concluded to undertake test 3-39 in a modified format, with an 820C test vehicle, as this presented the greatest likelihood of snagging or wedging the vehicle.

The critical impact point (CIP) was selected as being 4.0 meters upstream from the top of the trigger post, both as this is $L/2$ (the LON is at 8 meters from the trigger post) and because this CIP provides for the maximum penetration of the 820C into the barrier before impacting the trigger post. In addition, at this CIP the vehicle will be impacting the barrier before the cables transition down to the trigger post and therefore allows the greatest opportunity for the vehicle to become “wedged” between them. The modified Test 3-39 was completed without the use of a dummy mass. This resulted in the test inertial mass of the vehicle being 816 kg.

Crash Test

The Armorflex 4-Wire terminal end performed adequately in a reverse direction impact test 3-39 modified as seen in the Test Summary which is enclosed for reference. The vehicle remained stable and the direction of travel was not significantly altered as a result of impact with the test article. The detached parts of the barrier and terminal end, although projected some distance as a result of the vehicle impact, followed a similar trajectory to the vehicle so were considered not to pose a significant hazard to other road users and pedestrians any greater than that of vehicle itself. No detached elements, fragments, or other debris showed potential for penetrating the occupant compartment. There were no deformations recorded in the occupant compartment. The vehicle remained upright during and after the collision period. Occupant risk factors were low, and the exit trajectory of the test vehicle did not impose on adjacent lanes and remained within the limits imposed by NCHRP 350.

Findings

Therefore, the ATE-4 device described above and detailed in the enclosed drawings is acceptable for use on the NHS under the range of conditions tested, when acceptable to a highway agency.

Please note the following standard provisions that apply to FHWA letters of acceptance:

- This acceptance is limited to the crashworthiness characteristics of the devices and does not cover their structural features, nor conformity with the Manual on Uniform Traffic Control Devices.
- Any changes that may adversely influence the crashworthiness of the device will require a new acceptance letter.
- Should the FHWA discover that the qualification testing was flawed, that in-service performance reveals unacceptable safety problems, or that the device being marketed is significantly different from the version that was crash tested, we reserve the right to modify or revoke our acceptance.
- You will be expected to supply potential users with sufficient information on design and installation requirements to ensure proper performance.
- You will be expected to certify to potential users that the hardware furnished has essentially the same chemistry, mechanical properties, and geometry as that submitted for acceptance, and that it will meet the crashworthiness requirements of the FHWA and the NCHRP Report 350.
- To prevent misunderstanding by others, this letter of acceptance is designated as number CC-105 and shall not be reproduced except in full. This letter and the test documentation upon which it is based are public information. All such letters and documentation may be reviewed at our office upon request.
- The Armorwire ATE-4 terminals are patented products and considered proprietary. If proprietary devices are specified by a highway agency for use on Federal-aid projects, except exempt, non-NHS projects, (a) they must be supplied through competitive bidding with equally suitable unpatented items; (b) the highway agency must certify that they are essential for synchronization with the existing highway facilities or that no equally suitable alternative exists; or (c) they must be used for research or for a distinctive type of construction on relatively short sections of road for experimental purposes. Our regulations concerning proprietary products are contained in Title 23, Code of Federal Regulations, Section 635.411.

- This acceptance letter shall not be construed as authorization or consent by the FHWA to use, manufacture, or sell any patented device for which the applicant is not the patent holder. The acceptance letter is limited to the crashworthiness characteristics of the candidate device, and the FHWA is neither prepared nor required to become involved in issues concerning patent law. Patent issues, if any, are to be resolved by the applicant.

Sincerely,

A handwritten signature in blue ink, appearing to read "David A. Nicol". The signature is fluid and cursive, with the first name "David" being the most prominent.

David A. Nicol, P.E.
Director, Office of Safety Design
Office of Safety

Enclosures

TEST SUMMARY

HOLMES SOLUTIONS LIMITED, NEW ZEALAND
TEST NO. 5705-2-3-39M-1 // 7 AUG 2008

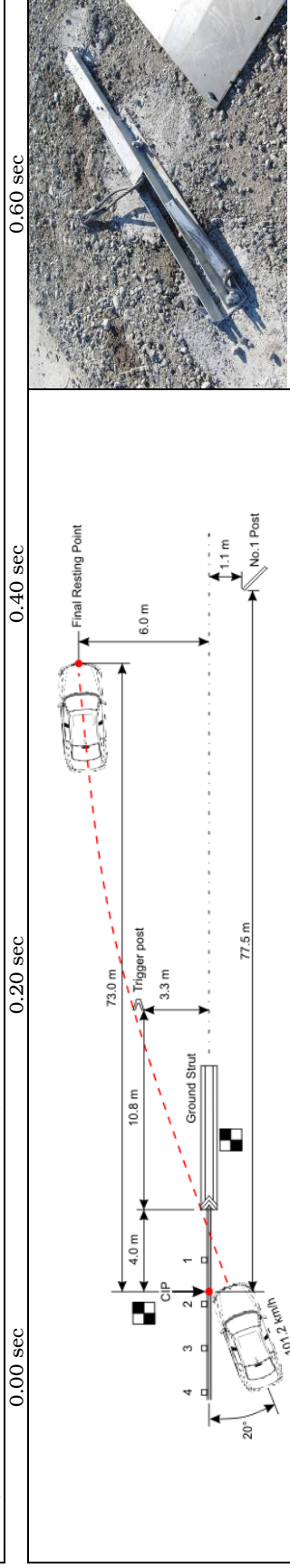
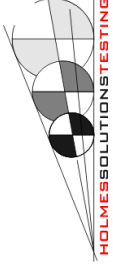

0.00 sec

0.20 sec

0.40 sec

0.60 sec

• TEST ARTICLE

Armorflex 4-wire rope terminal end with Nucor 4 lb Rib-bak posts. Reverse angle hit.

• CIP

4.0 metres upstream of terminal end trigger post.

• POST IMPACT BEHAVIOUR

Vehicle Stability..... Satisfactory
 Stopping Distance... 73 m downstream of CIP
 Max. Roll angle..... 7.5 (3.0162 sec)
 Max. Pitch angle.... -14.8 (2.1049 sec)
 Max. Yaw angle..... -45.4 (2.5930 sec)

• OCCUPANT RISK VALUES

IMPACT VELOCITY (M/S - FRONT OF INTERIOR)
 x-direction..... 5.0 (0.1592 sec)
 y-direction..... -3.7 (0.1592 sec)
 THIV 6.2 (22.4 km/h at 0.1630 sec)
 RIDEDOWN DECELERATIONS (G)
 x-direction..... -4.9 (0.2104 - 0.2204 sec)
 y-direction..... -3.9 (0.1598 - 0.1698 sec)
 PHD 5.0 (0.2105 - 2205)
 ASI 0.58 (0.0616 - 0.1116 sec)
 MAX. 0.050 SECOND AVERAGE (G)
 x-direction..... -5.6 (0.1269 - 0.1769 sec)
 y-direction..... 4.0 (0.2949 - 0.3449 sec)
 z-direction..... 2.9 (0.1526 - 0.2026 sec)

• IMPACT CONDITIONS

Impact Speed 101.2 km/h
 Impact Angle 20°
 Exit Speed n/a
 Exit Angle n/a

• TEST ARTICLE DEFLECTIONS (METRES)

Test Article Damage... Moderate
 Dynamic..... n/a
 Permanent..... n/a
 Working Width..... n/a

• VEHICLE DAMAGE - EXTERIOR

VDS..... 11-LFQ-5
 CDC..... 11-FYML5
 Max Deformation 450 mm LF corner

• VEHICLE DAMAGE - INTERIOR

OCDI..... AS00000000
 Max. Deformation 0.0 mm

• TEST VEHICLE

Designation..... 820C - Small Car
 Make/Model..... 1996 Toyota Starlet
 Dimensions (lwh).... 3740 x 1600 x 1380
 Test Weight..... 816 kg

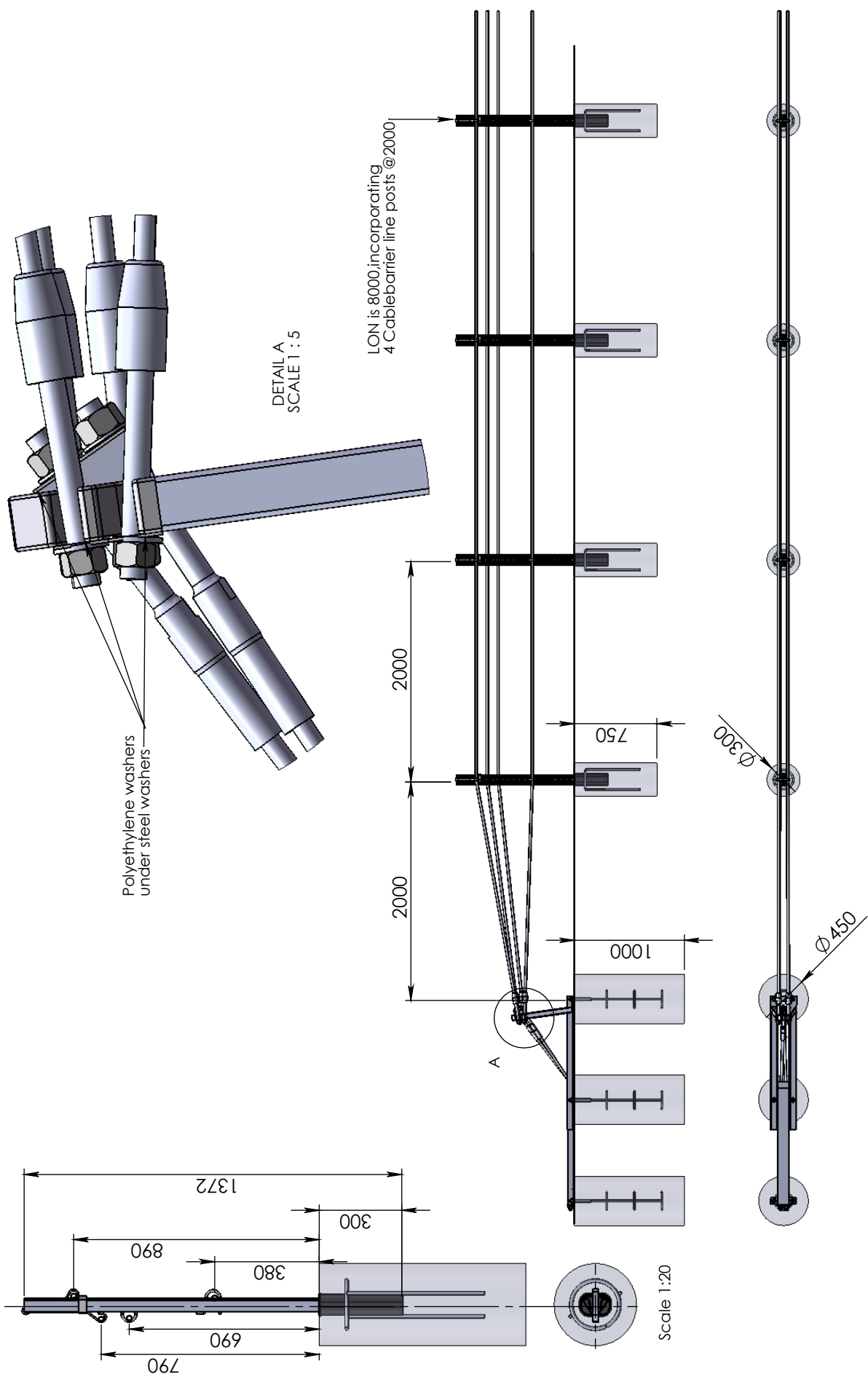

Standard Tolerance

SCALE: 1:50

DRAWN BY	DATE	INIT.
APPR'D BY		AD
		DJ

8 Paul Matthews Rd.
Albany, Auckland, NZ
tel. 64 9 415 2991
fax. 64 9 415 2993
info@armorflex.co.nz

ARMORFLEX
New Zealand

Cable Barrier
Plan and Elevation

SHEET 1 OF 1

DRAWING NUMBER

REV.

The information herein is proprietary to Armorflex Ltd. and shall not be disclosed, duplicated or used otherwise without the express written approval of Armorflex Ltd.

© 2007 Armorflex Ltd.

CHANGES

DATE

REV.